

超硬付 With a carbide tip

レースセンター Lathe Centers

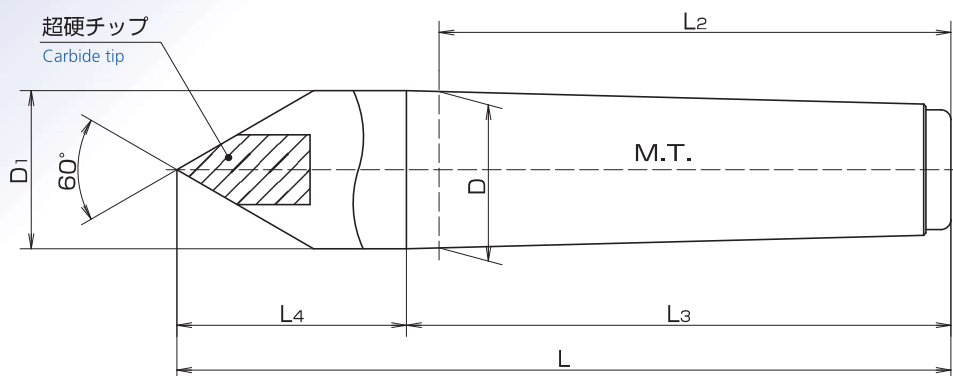
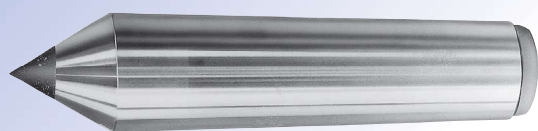

● 主要仕様 Main specs

単位 unit: mm

コードNo. Code No.	M.T.	D	D1	L	L2	L3	L4	超硬径 Carbide tip diameter
ZLC1-001	No.1	12.065	12.2	82	53.5	57	25	6
ZLC2-001	No.2	17.780	18.0	100	64.0	69	31	8
ZLC3-001	No.3	23.825	24.1	125	81.0	86	39	10
ZLC4-001	No.4	31.267	31.6	155	102.5	109	46	14
ZLC5-001	No.5	44.399	44.7	200	129.5	136	64	18
ZLC6-001	No.6	63.348	63.8	270	182.0	190	80	30

〈先端円錐部全超硬付〉 With a carbide tip for the tip of the conical part

コードNo. Code No.	M.T.	D	D1	L	L2	L3	L4	超硬径 Carbide tip diameter
ZLC2-003	No.2	17.780	18.0	100	64	69	31	18
ZLC3-003	No.3	23.825	24.1	125	81	86	39	24.1
ZLC4-003	No.4	31.267	31.6	155	102.5	109	46	31.6

■センターの振れ(最大)M.T.に対する先端60°部の振れTIR 0.005
The runout of the 60-degree tip part with respect to the center runout (max)
M.T.: TIR 0.005

(寸法は設計変更により変わることがあります)
(Dimensions are subject to change due to design modifications.)

● 特長 Characteristics

- 各種機械、円筒研削盤に使用されます。
- 特殊形状チップ付き、リング状チップ付き、抜きナット付き、全長の長いレースセンターも別注にて製作いたします。

- Used for machines and cylindrical grinding machines.
- We can also produce lathe centers mounted with a specially shaped tip, a ring-shaped tip or a removable nut, or a lathe center with an extended overall length, if ordered separately.